

## **SERVICE SCHEDULE - E-LAN SERVICE**

**NUCLEUS CONNECT PTE. LTD.**  
**INTERCONNECTION OFFER (ICO) AGREEMENT**  
**SERVICE SCHEDULE – E-LAN SERVICE**

## CONTENT PAGE

<u>No.</u>	<u>Paragraph</u>	<u>Page</u>
1.	INTRODUCTION .....	4
2.	DEFINITIONS AND INTERPRETATION.....	4
3.	COMMENCEMENT .....	6
4.	SERVICE REQUIRMENTS .....	6
5.	CHARGES.....	9
6.	CHANGES FROM THE GENERAL SERVICE TERMS AND CONDITIONS.....	13

## **1. INTRODUCTION**

- 1.1 This Service Schedule sets out the terms and conditions under which Nucleus Connect will provide the service known as E-LAN Service (as defined below) to the Contracting QP.
- 1.2 This Service Schedule comprises the following:
- (a) the provisions herein;
  - (b) subject to paragraph 6, the General Service Terms and Conditions and the following Appendices:
    - (i) Appendix 1: Provisioning Timeframe;
    - (ii) Appendix 2: Service Level Guarantees; and
  - (c) Orders submitted by the Contracting QP in relation to this Service Schedule.
- 1.3 In the event of any inconsistency or conflict between the provisions herein, the General Service Terms and Conditions and Orders submitted by the Contracting QP in relation to this Service Schedule, the order of precedence shall be as follows:
- (a) the provisions herein;
  - (b) Orders submitted by the Contracting QP in relation to this Service Schedule; and
  - (c) the General Service Terms and Conditions.
- 1.4 The Master ICO Agreement, including the Annexes, shall apply unless and to the extent amended or supplemented by the provisions of this Service Schedule.
- 1.5 In this Service Schedule, a reference to a paragraph, unless stated otherwise, is to a paragraph of this Service Schedule.

## **2. DEFINITIONS AND INTERPRETATION**

- 2.1 Unless otherwise defined herein this Service Schedule, all terms and expressions used herein will be construed to have the same meanings as found in the Master ICO Agreement and the General Service Terms and Conditions. Where a term or expression is defined specifically in this Service Schedule herein, the provisions herein shall prevail.
- 2.2 In this Service Schedule:
- |                           |   |
|---------------------------|---|
| Approved Project Schedule | has the meaning ascribed to it in paragraph 6.1(c) or 6.1(e), as the case may be;   |
| Class of Service or CoS   | means any of the following class of service: <ul style="list-style-type: none"><li>(a) Class A Real Time (Class A);</li><li>(b) Class B Near Real Time (Class B);</li><li>(c) Class C Mission Critical (Class C); or</li><li>(d) Class D Best Effort (Class D),</li></ul> each of which is prescribed QoS parameters as set out in the table in paragraph 4.2(c); |

Committed Information Rate (CIR)	means the minimum bandwidth that Nucleus Connect guarantees over the A-B segment of the diagram in the definition of “QoS”, for each E-LAN Connection;
Downlink	means bandwidth in the downstream direction (from Aggregation Network to the End-User);
E-LAN Connection	means a layer 2 ethernet connection that allows End-Users to communicate transparently and directly with other End-Users within the same E-LAN Domain;
E-LAN Domain	means a virtual layer 2 transparent local area network that originate from the Contracting QP and allows any E-LAN Connection to communicate with any other E-LAN Connection whereby (a) each E-LAN Domain shall be uniquely provided to each Contracting QP and (b) the Contracting QP shall be able to acquire more than one E-LAN Domain but subject to the availability of Nucleus Connect’s Network resources. Each E-LAN Domain shall be configured with a Class of Service and a VLAN type/value (IEEE802.1q or IEEEQ-in-Q). Only E-LAN Connection of the same Class of Service and VLAN type/value can join this E-LAN Domain;
E-LAN Service	means E-LAN Connection and/or E-LAN Service Port;
E-LAN Service Port	means the physical port whereby E-LAN Connection(s) will be delivered to the End-User;
NBAP E-LAN Service Port	has the meaning ascribed to it in paragraph 6.1;
Peak Information Rate (PIR)	means the maximum bandwidth that an E-LAN Connection can reach over the A-B segment of the diagram in the definition of “QoS”, in the absence of any sort of traffic aggregation, congestion or multiplexing;

Quality of Service or (QoS) means the service levels committed for ensuring delivery of services over the A-B segment of the diagram below, measured by Jitter, Latency and Packet Loss as set out in the table in paragraph 4.2(c);

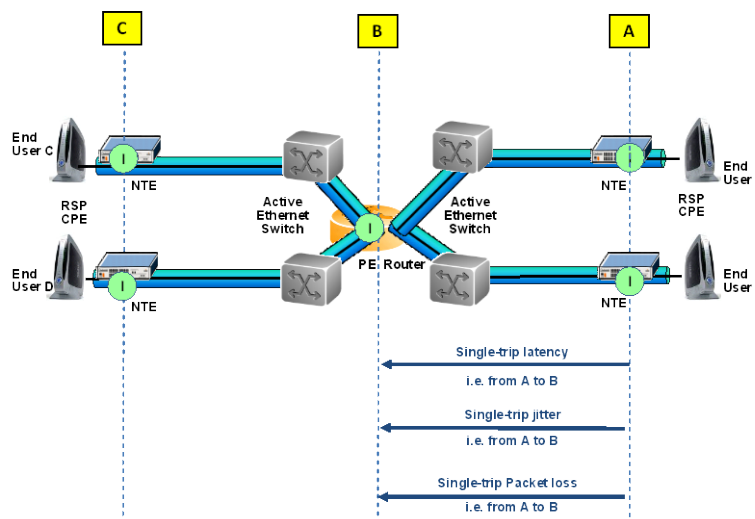

Service Port ID means an identification number assigned by Nucleus Connect to an E-LAN Service Port that has been provisioned for the Contracting QP;

Symmetrical means equal bandwidth for Uplink and Downlink (between the End-User and the Aggregation Network); and

Uplink means bandwidth in the upstream direction (from the End-User to the Aggregation Network).

### 3. COMMENCEMENT

This Service Schedule shall commence with effect from the date that the Contracting QP first places an Order to take up an E-LAN Service, in accordance with the General Service Terms and Conditions.

### 4. SERVICE REQUIREMENTS

4.1 The Contracting QP shall place one (1) Order for each E-LAN Connection. For example, if the Contracting QP wishes to take up two (2) E-LAN Connections, the Contracting QP shall submit two (2) separate Orders.

4.2 When placing an Order for an E-LAN Connection, the Contracting QP shall be required to:

- (a) Specify one (1) E-LAN Service Port type and the address of the installation location, except that where any such installation location is an NBAP, the Contracting QP is required to provide Global Positioning System (GPS) co-ordinates and description of such installation location. The E-LAN Service Port may be new or then existing and if the latter, the Contracting QP shall be required to specify the Service Port ID in respect of such E-LAN Service Port.

The E-LAN Service Port type is either Fast Ethernet (“**FE Service Port**”) or Gigabit Ethernet (“**GE Service Port**”).

For FE Service Port(s), each E-LAN Connection will have a Symmetrical PIR of 100Mbps.

For GE Service Port(s), each E-LAN Connection will have a Symmetrical PIR of 1Gbps.

In the case of multiple E-LAN Connections sharing the same E-LAN Service Port, the number of Media Access Control (MAC) addresses that can be configured per E-LAN Connection is two (2). Additional MAC addresses may be configured per E-LAN Connection subject to the availability of Nucleus Connect’s Network resources.

- (b) Specify the following Network protocol options:
- (i) VLAN (IEEE 802.1q), VLAN(IEEEQ-in-Q) or without VLAN. In the case of multiple E-LAN Connections sharing the same E-LAN Service Port, the maximum number of VLANs that can be configured per E-LAN Service Port is sixteen (16); and
  - (ii) E-LAN Domain.

Each E-LAN Connection can only be connected to one (1) E-LAN Domain of the same Class of Service and VLAN type/value, at all times.

- (c) Subscribe to only one (1) Class of Service for such E-LAN Connection and indicate the total Symmetrical CIR it wishes to purchase in blocks of 5Mbps, provided that:
- (i) the Symmetrical CIR for such Class of Service shall be no more than 100Mbps for FE Service Port, and 1Gbps for GE Service Port;
  - (ii) such Class of Service shall have a minimum Symmetrical CIR of 25Mbps; and
  - (iii) where there are multiple E-LAN Connections sharing the same E-LAN Service Port, the aggregate Symmetrical CIR for such E-LAN Connections shall be no more than 100Mbps for FE Service Port, and 1Gbps for GE Service Port.

The Contracting QP may subsequently from time to time, increase or decrease the Symmetrical CIR of the Class of Service subscribed for such E-LAN Connection, in blocks of 5Mbps, provided that sub-paragraphs (i) to (iii) above are complied with. Such increase or decrease of Symmetrical CIR shall constitute a Modification for which the Contracting QP shall be required to submit an Order pursuant to and in accordance with the General Service Terms and Conditions.

The tables below show the performance parameters of the Classes of Services for E-LAN Connection.

<b>Class Of Service</b>	<b>Jitter</b>	<b>Latency</b>	<b>Packet Loss</b>
Class A Real Time	1ms	8ms	0.1%

Class B Near Real Time	1ms	15ms	0.1%
Class C Mission Critical	4ms	20ms	0.05%
Class D Best Effort	Best Effort	60ms	Best Effort

- 4.3 If the Contracting QP injects traffic into any E-LAN Connection which exceeds the Symmetrical CIR purchased pursuant to paragraph 4.2(c), the Contracting QP acknowledges and agrees that notwithstanding that Nucleus Connect will endeavour to deliver such excess traffic, such delivery is not guaranteed. For the avoidance of doubt, the Contracting QP shall not be able to inject traffic into any E-LAN Connection which exceeds the PIR as set out in paragraph 4.2(a).
- 4.4 In the case where the Contracting QP sends out MAC-layer multicast traffic into an E-LAN Connection, such traffic shall be allowed to pass through transparently through Nucleus Connect's Network and the subscribed Class of Service shall apply accordingly.
- 4.5 Only one Class of Service and VLAN type/value is supported per E-LAN Connection. An E-LAN Service Port can support multiple E-LAN Connections to different E-LAN Domains.
- 4.6 The Contracting QP must adhere to Nucleus Connect's QoS tagging scheme when sending or receiving data traffic through any E-LAN Connection from the relevant Service Port(s). Such QoS tagging scheme requires the use of priority bit value 5 for Class A, priority bit value 4 for Class B, priority bit value 2 for Class C and priority bit value 1 for Class D.
- 4.7 In relation to any E-LAN Service taken up by the Contracting QP, if the Contracting QP wishes to:
- (a) change the then existing E-LAN Service Port type in respect of such E-LAN Service (from FE Service Port to GE Service Port or vice versa); and/or
  - (b) change the Class of Service for the then existing E-LAN Domain,
- each such event shall constitute a Modification for which the Contracting QP shall be required to submit an Order pursuant to and in accordance with the General Service Terms and Conditions.
- 4.8 If, in relation to an Order to take up an E-LAN Service, the installation location required is a Non-Residential Premises and the Contracting QP indicates to Nucleus Connect in such Order that it does not require OpenNet to provide the fibre and in-building cabling between the FTTB Node and the 1<sup>st</sup> TP for the relevant Non-Residential Building, the Contracting QP shall be responsible for the supply and maintenance of such fibre and in-building cabling. In such event, the Contracting QP acknowledges and agrees that:
- (a) the Contracting QP shall bear the following charges:
    - (i) ON Charges, except those ON Charges which would be subject to paragraph 4.8(a)(iii), which have been incurred by Nucleus Connect, or which Nucleus Connect has committed to incur, in connection therewith;

- (ii) any Third Party Charges which have been incurred by Nucleus Connect, or which Nucleus Connect has committed to incur, in connection therewith; and
  - (iii) any other third party charges, OpenNet's charges and/or ON Charges agreed pursuant to paragraph 5.2 or 6.3 of the General Service Terms and Conditions which have been incurred by Nucleus Connect, or which Nucleus Connect has committed to incur, in connection therewith;
- (b) the Contracting QP shall provide fibre and in-building cabling from the FTTB Node and up to and including the 1<sup>st</sup> TP that is of a quality that is fit-for-purpose; and
- (c) the Contracting QP shall make such fibre and in-building cabling from the FTTB Node and up to and including the 1<sup>st</sup> TP, available and ready for Nucleus Connect's use at least three (3) Business Days before the RFS Date in respect of such E-LAN Service.

For the avoidance of doubt, if the Contracting QP fails to comply with sub-paragraphs (b) and (c) above and due to such failure, Nucleus Connect is not able to provision and activate such E-LAN Service by the scheduled RFS Date, the Contracting QP shall not be entitled to make any claim under Appendix 1 of the General Service Terms and Conditions, and Nucleus Connect shall be entitled to commence charging the Contracting QP the Monthly Recurring NC Charges set out in paragraph 5.1 on such scheduled RFS Date (and not the delayed date that such E-LAN Service is in fact activated).

**5. CHARGES**

The Charges set out in this paragraph 5 are the rates payable by the Contracting QP on an E-LAN Connection and an E-LAN Service Port basis.

**5.1 Monthly Recurring NC Charges**

Nucleus Connect will commence charging the Contracting QP the Monthly Recurring NC Charges specified below on the RFS Date.

<b>E-LAN Connection</b>		<b>Monthly Recurring NC Charge</b>	
		<b>First 25Mbps</b>	<b>Next 5Mbps</b>
Class of Service	Real Time	\$244	\$48.80
	Near Real Time	\$208	\$41.60
	Mission Critical	\$161	\$32.20
	Best Effort	\$125	\$25.00

<b>E-LAN Service Port</b>		<b>Monthly Recurring NC Charge</b>
FE (100Mbps) Service Port	Residential Premise	\$25
	Non-Residential Premise	\$100
	NBAP	\$380
GE (1Gbps) Service Port	Non-Residential Premise	\$600
	NBAP	\$930

5.2 One-Time Charges

The Charges set out below are non-refundable once they are imposed on the Contracting QP by Nucleus Connect in the manner specified below. In addition, depending on when the relevant action is preferred by the Contracting QP to be undertaken by Nucleus Connect, the following multiplier factor will be applied to the NC Charges set out below. For the avoidance of doubt, the multiplier factor to be applied shall be one (1) unless the Contracting QP requests that the relevant action be undertaken by Nucleus Connect on off-working hours during Business Day(s) or on non Business Day(s).

	<b>Period</b>	<b>Time</b>		<b>Multiplier Factor</b>
Business Day	Monday to Friday	Working Hours	9.00am to 5.00pm	1
	Monday to Friday	Off-working hours	Before 9am and after 5.00pm	1.5
Non-Business day	Saturday, Sundays and Public Holidays	Throughout		2

(a) Cancellation Charge

Upon any Cancellation of any Order or Approved Project Schedule by the Contracting QP, the following Charges shall be imposed on the Contracting QP:

- (i) an NC Charge of \$50 if Cancellation happens before Nucleus Connect's acknowledgement of its receipt of the Order or an NC Charge of an amount equal to the applicable NC Charges as set out in paragraph 5.2 if Cancellation happens after Nucleus Connect's acknowledgement of its receipt of the Order;
- (ii) ON Charges, except those ON Charges which would be subject to paragraph 5.2(a)(iv), which have been incurred by Nucleus Connect, or which Nucleus Connect has committed to incur, at the time of such Cancellation Charge;
- (iii) any Third Party Charges which have been incurred by Nucleus Connect, or which Nucleus Connect has committed to incur, at the time of such Cancellation; and
- (iv) any other third party charges, OpenNet's charges and/or ON Charges agreed pursuant to paragraph 5.2 or 6.3 of the General Service Terms and Conditions which have been incurred by Nucleus Connect, or which Nucleus Connect has committed to incur, at the time of such Cancellation.

(b) Installation Charge

- (i) Upon the installation of an E-LAN Connection by Nucleus Connect, the following Charges shall be imposed on the Contracting QP on a per E-LAN Service Port basis:
  - (a) the following NC Charges:

<b>Description</b>		<b>One-Time Charges</b>
Installation Charge	Residential Premise	\$50
	Non-Residential Premise	\$350
	NBAP	\$1,500
Installation of environmental hardened NTE (at the request of the Contracting QP for Service Port at Non-Residential Premises, or as part of the NBAP E-LAN Service Port installation)		\$500
Per E-LAN Domain Setup Charge. Applicable only for the first time set up of the E-LAN Domain.		\$1,000 per E-LAN domain. Applicable only for the first time set up of the E-LAN

Provided that if it becomes necessary for Nucleus Connect to install an environmental hardened NTE as part of the installation of such E-LAN Service, Nucleus Connect shall seek the Contracting QP's prior consent to such installation of the environmental hardened NTE in accordance with the process set out in paragraph 6.1. If the Contracting QP does not provide such consent in accordance with the process set out in paragraph 6.1, the Contracting QP acknowledges and agrees that the Order in respect of such E-LAN Service shall be deemed to be Cancelled whereupon paragraph 5.2(a) shall apply; and

- (b) if applicable, such other installation Charges as may be set out in the Approved Project Schedule.
- (ii) Patching Charge in the NC CO and Co-location Space
  - (a) A Patching Charge in addition to the Installation Charge will be imposed if Nucleus Connect is required to provide Patching Services. Nucleus Connect may be required to provide Patching Services where the installation address is located at the Co-location Space or the NC CO. This will be charged at \$40 per patch point.
  - (b) This Patching Service will be provided by Nucleus Connect if required. The Contracting QP will be required to submit a separate Order for this Patching Service.
- (c) Modification Charge

The NC Charges set out below shall be imposed on the Contracting QP upon the submission of a Modification Order by the Contracting QP:

- (i) where such Modification Order relates to the E-LAN Connection or E-LAN Service Port, \$200; or
- (ii) where such Modification Order relates to E-LAN Domain, \$750.

(d) Maintenance or Repair

- (i) Nucleus Connect will charge for every onsite visit or joint investigation, according to the length of time spent by Nucleus Connect's representative during such onsite visit or joint investigation respectively, if such onsite visit or joint investigation is requested by the Contracting QP. There will be a minimum charge of \$400 per onsite visit or joint investigation (as the case may be) up to the first two hours. Subsequent hour blocks are charged at \$200 per hour.
- (ii) The No Fault Found Charge referred to in the General Service Terms and Conditions is \$350 per Fault report.
- (iii) In the event that routine maintenance of the NBAP E-LAN Service Port requires the use of safety gear, equipment and/or escort and access by qualified personnel, such requirement shall be provided by the Contracting QP to Nucleus Connect at the Contracting QP's cost, unless Nucleus Connect is reasonably expected to own and provide the same.

(e) Disconnection

Upon a disconnection of an E-LAN Service by reason of suspension pursuant to the ICO Agreement, an NC Charge of \$300 shall be imposed on the Contracting QP.

(f) Deactivation

Upon the Deactivation of an E-LAN Service, the following Charges shall be imposed on the Contracting QP:

- (i) the following NC Charges:

Description	Charges
Deactivation Charge	\$300
Early Termination Charge	100% of remaining contract value

- (ii) ON Charges, except those ON Charges which would be subject to paragraph 5.2(f)(iv), which have been incurred by Nucleus Connect, or which Nucleus Connect has committed to incur, at the time of such Deactivation;
- (iii) any Third Party Charges which have been incurred by Nucleus Connect, or which Nucleus Connect has committed to incur, at the time of such Deactivation; and
- (iv) any other third party charges, OpenNet's charges and/or ON Charges agreed pursuant to paragraph 5.2 or 6.3 of the General Service Terms and Conditions which have been incurred by Nucleus Connect, or which Nucleus Connect has committed to incur, at the time of such Deactivation.

**6. CHANGES FROM THE GENERAL SERVICE TERMS AND CONDITIONS**

**6.1 Paragraph 5.1 of the General Service Terms and Conditions**

For the purpose of this Service Schedule, where the Contracting QP requires the E-LAN Service Port to be installed at an NBAP ("**NBAP E-LAN Service Port**"), paragraph 5.1 of the General Service Terms and Conditions shall not apply and the following provisions of this paragraph 6.1 shall apply instead:

- “(a) The Contracting QP acknowledges and agrees that in order for Nucleus Connect to provide the NBAP E-LAN Service Port to the Contracting QP, Nucleus Connect will need to request OpenNet to provide Nucleus Connect with the relevant NBAP connection, which will (if such request is accepted by OpenNet) involve a project study being undertaken by OpenNet (the "**OpenNet Project Study**").
- (b) If an Order to take up an NBAP E-LAN Service Port is not rejected by Nucleus Connect, Nucleus Connect will provide a project schedule (the "**Project Schedule**") to the Contracting QP within ten (10) Business Days from the completion of the OpenNet Project Study stating (i) the period within which Nucleus Connect will activate such NBAP E-LAN Service Port, (ii) an estimation of Nucleus Connect's, OpenNet's and any third party charges involved and (iii) such other terms and conditions relating to the provision of such NBAP E-LAN Service Port as Nucleus Connect may specify. In addition, in situations where OpenNet requires Nucleus Connect to agree on certain ON Charges and Nucleus Connect intends to on-pass such ON Charges to the Contracting QP, Nucleus Connect and the Contracting QP shall also agree on such ON Charges before Nucleus Connect proceeds to incur such ON Charges.
- (c) The Contracting QP will be able to raise to Nucleus Connect any terms that are not acceptable to it in the Project Schedule within five (5) Business Days from its receipt thereof, failing which the Contracting QP shall be deemed to have accepted and agreed to the terms in the Project Schedule in its entirety and such Project Schedule shall constitute an Approved Project Schedule.
- (d) If the Contracting QP and Nucleus Connect are unable to reach a mutual agreement on the terms of a Project Schedule within ten (10) Business Days after such Project Schedule is made available to the Contracting QP:
  - (i) the Order which is the subject of such Project Schedule shall be deemed to be Cancelled whereupon paragraph 5.2(a) shall apply; and
  - (ii) such Project Schedule and this Service Schedule shall lapse, unless Nucleus Connect is separately providing E-LAN Service to the Contracting QP at the time, in which case this Service Schedule shall remain in force.

Nucleus Connect shall not unreasonably reject the Contracting QP's request for extension of the said ten (10) Business Days timeframe to reach a mutual agreement on the terms of the Project Schedule.

- (e) As soon as practicable after the mutual agreement of the Contracting QP and Nucleus Connect to the terms of a Project Schedule (as modified or with such additional terms as the Contracting QP and Nucleus Connect may require), the Contracting QP shall confirm in writing to Nucleus Connect that the Contracting QP agrees to the terms of such Project Schedule in their entirety

(and such agreed Project Schedule shall hereinafter be referred to as an “**Approved Project Schedule**”) within the ten (10) Business Days timeframe (or as the case may be, the agreed extended timeframe) referred to in paragraph 6.1(d) above, whereupon the Approved Project Schedule shall be binding on Nucleus Connect and the Contracting QP.

- (f) If the Contracting QP subsequently does not wish to proceed with an Approved Project Schedule, that shall be deemed to be a Cancellation whereupon paragraph 5.2(a) shall apply.”

# Application Form

## Layer 2 Ethernet LAN Service (E-LAN)



ATTN: NUCLEUS CONNECT, ORDER DESK  
 FACSIMILE NO. : (65) 6808 2820  
 EMAIL: [orderdesk@nucleusconnect.com](mailto:orderdesk@nucleusconnect.com)

### Business Customer Information

Company Details	Authorised Officer Particulars
Name of Firm/Company as in RCB:	Name of Authorised Officer as in NRIC/PASSPORT/FIN*. Please underline surname. (Dr/Mr/Miss/Mrs/Mdm):_
Registered Address as in RCB:	NRIC/PASSPORT/FIN* No. of Authorised Officer (Dr/Mr/Miss/Mrs/Mdm):
	E-mail of Authorized Officer:
Main Office Contact No.:	Designation:
Main Office Fax No.:	Contact No. (Office):_
Business Registration Number (BRN):	Contact No. (Fax):
Account Information (For New Accounts, please refer to <a href="http://www.nucleusconnect.com">www.nucleusconnect.com</a> for instruction to sign up Nucleus Connect's Services)	<input type="checkbox"/> Account Number:
Customer Reference ID : (This ID is issued by customer for their internal reference of the service that is set out in this application form)	

### Billing Details (If different from Business Customer Information)

Company Name:	Billing Address :_
City & Postal Code:	Country:
Contact Person Name (Billing):	Customer Contact Number :
Customer Fax Number:	E-mail:

\* Please select where appropriate

### Customer Technical Contact

Installation Contact (for service delivery)	Operations/Technical Contact (after service delivery)
Name:	Name:
Telephone (O):	Telephone (O):
Mobile:	Mobile:
Email:	Email:
Notification Mode: 24 Hours Daily <input type="checkbox"/> Office Hours (9am-5pm, Mon-Fri) <input type="checkbox"/>	Notification Mode: 24 Hours Daily <input type="checkbox"/> Office Hours (9am-5pm, Mon-Fri) <input type="checkbox"/>

\* Please select where appropriate

### E-LAN Service Port

<input type="checkbox"/> New Order <input type="checkbox"/> Modification <input type="checkbox"/> Deactivation <input type="checkbox"/> Others (Please specify): _____		
Existing Service Port ID (Mandatory field unless New Order): _____		
<input type="checkbox"/> Fast Ethernet UTP (100Mbps) <input type="checkbox"/> Gigabit Ethernet UTP (1Gbps) <input type="checkbox"/> Environmental hardened NTE is required	<input type="checkbox"/> Residential <input type="checkbox"/> Non-Residential <input type="checkbox"/> Non-Building Address Point (NBAP)	
Service Port Installation Location	Address:	Postal Code:
Installation Location not within a addressable room (e.g NBAP, Non-residential)	GPS Co-ordinate: _____ Elevation above floor: _____	Description: _____
Site Contact:	Name:	Contact number:

# Application Form

## Layer 2 Ethernet LAN Service (E-LAN)



Instruction					
Class of Services option: <ul style="list-style-type: none"> <li>Class A (Real Time),</li> <li>Class B (Near Real Time),</li> <li>Class C (Mission Critical) and</li> <li>Class D (Best Effort)</li> </ul>	E-LAN Connection option: <ul style="list-style-type: none"> <li>Only 1 Class of Service per E-LAN Connection</li> <li>Minimum subscription of 25Mbps per Connection</li> <li>Total subscribed bandwidth per connection is in blocks of 5Mbps</li> </ul>	E-LAN Domain: <ul style="list-style-type: none"> <li>Only 1 "New", "Modification" or "Deactivation" of E-LAN Domain per Application form</li> <li>Only 1 Class of Service per E-LAN Domain</li> <li>Only 1 VLAN type/value is support at all times</li> </ul>			
E-LAN Domain					
<input type="checkbox"/> New    Class of Service : _____		<input type="checkbox"/> Modification Existing E-LAN Domain ID: _____                      Class of Service : _____		<input type="checkbox"/> Deactivation	
E-LAN Connection Configuration					
E-LAN Domain ID	E-LAN Connection Service ID	Class of Service	Network Protocol Options	Symmetrical CIR Bandwidth	VLAN
<input type="checkbox"/> New E-LAN Domain  <input type="checkbox"/> Existing E-LAN Domain ID: _____	<input type="checkbox"/> New <input type="checkbox"/> Modification <input type="checkbox"/> Deactivation  <input type="checkbox"/> Existing Connection ID: _____	<input type="checkbox"/> Class A <input type="checkbox"/> Class B  <input type="checkbox"/> Class C <input type="checkbox"/> Class D	<input type="checkbox"/> L2 VLAN IEEE802.1q <input type="checkbox"/> L2 VLAN IEEEQ-in-Q <input type="checkbox"/> untagged	Bandwidth : _____	VLAN : _____
Contract Period					
Minimum Term <sup>Ⓐ</sup>	<input type="checkbox"/> 12 Months <input type="checkbox"/> Others (Please specify): _____				
Customer requested RFS Date <sup>Ⓐ</sup>	_____				
OpenNet Appointment Date <sup>Ⓐ#</sup>	Date:	Slot:	AM <input type="checkbox"/>	PM <input type="checkbox"/>	
Nucleus Connect Appointment Date <sup>**#</sup>	Date:	Slot:	AM <input type="checkbox"/>	PM <input type="checkbox"/>	EVENING <sup>®</sup> (After 5pm) <input type="checkbox"/>
Additional Information					
Requires OpenNet to provide the fibre and in-building cabling between the FTTB Node and 1 <sup>st</sup> TP for the Non-Residential Building: <u>Yes/No*</u>					
Others:					

<sup>Ⓐ</sup> Subject to agreement, resource availability and confirmation by Nucleus Connect.  
<sup>Ⓐ</sup> If Minimum Term is not specified, the Contracting QP shall be deemed to have selected 12 months.  
<sup>Ⓐ</sup> Timeslot is not available on weekends and public holidays  
<sup>#</sup> NC Multiplier factor / OpenNet Onsite Charges shall apply accordingly.  
<sup>Ⓐ</sup> OpenNet appointment is required if there is a installation of a termination point

\*\* When there is a termination point installation, Nucleus Connect's appointment shall be no more than 3 Business Days after OpenNet's appointment date.

# Application Form

## Layer 2 Ethernet LAN Service (E-LAN)



Customer Signature		
<p>We hereby agree to subscribe to the above mentioned services on the terms and subject to the conditions contained in the Master ICO Agreement and the Service Schedule for the abovementioned services, which terms and conditions shall apply upon Nucleus Connect's acceptance of this application. We certify that all information provided by us herein are true, correct and complete. Further, we agree that any cancellation of the abovementioned services may result in a charge to us at Nucleus Connect's prevailing rates.</p>		
<u>Signature of Authorised Officer</u>	<u>Date</u>	<u>Company Stamp</u>
For Nucleus Connect Use		
<input type="checkbox"/> Application Rejected:	Reason for rejection:	
<input type="checkbox"/> Application Accepted	Service ID/s:	Work Order No.:
No. of pages attached (Excluding application forms):	Approval code:	Processed by (Name, Contact, Signature and Date)