

## **SERVICE SCHEDULE – NBAP PER-END-USER CONNECTION**

**NUCLEUS CONNECT PTE. LTD.**  
**INTERCONNECTION OFFER (ICO) AGREEMENT**  
**SERVICE SCHEDULE – NBAP PER-END-USER CONNECTION**

## CONTENT PAGE

<u>No.</u>	<u>Paragraph</u>	<u>Page</u>
1.	INTRODUCTION .....	4
2.	DEFINITIONS AND INTERPRETATION.....	4
3.	COMMENCEMENT .....	5
4.	SERVICE REQUIRMENTS .....	6
5.	CHARGES .....	8
6.	CHANGES FROM THE GENERAL SERVICE TERMS AND CONDITIONS.....	11

**1. INTRODUCTION**

- 1.1 This Service Schedule sets out the terms and conditions under which Nucleus Connect will provide the service known as NBAP Per-End-User Connection (as defined below) to the Contracting QP.
- 1.2 This Service Schedule comprises the following:
- (a) the provisions herein;
  - (b) subject to paragraph 6, the General Service Terms and Conditions and the following Appendices:
    - (i) Appendix 1: Provisioning Timeframe;
    - (ii) Appendix 2: Service Level Guarantees; and
  - (c) Orders submitted by the Contracting QP in relation to this Service Schedule.
- 1.3 In the event of any inconsistency or conflict between the provisions herein, the General Service Terms and Conditions and Orders submitted by the Contracting QP in relation to this Service Schedule, the order of precedence shall be as follows:
- (a) the provisions herein;
  - (b) Orders submitted by the Contracting QP in relation to this Service Schedule; and
  - (c) the General Service Terms and Conditions.
- 1.4 The Master ICO Agreement, including the Annexes, shall apply unless and to the extent amended or supplemented by the provisions of this Service Schedule.
- 1.5 In this Service Schedule, a reference to a paragraph, unless stated otherwise, is to a paragraph of this Service Schedule.

**2. DEFINITIONS AND INTERPRETATION**

- 2.1 Unless otherwise defined herein this Service Schedule, all terms and expressions used herein will be construed to have the same meanings as found in the Master ICO Agreement and the General Service Terms and Conditions. Where a term or expression is defined specifically in this Service Schedule herein, the provisions herein shall prevail.
- 2.2 In this Service Schedule:

Approved Project Schedule	has the meaning ascribed thereto in paragraph 6.1(c) or 6.1(e), as the case may be;
Class of Service or CoS	means any of the following class of service: <ul style="list-style-type: none"><li>(a) Class A Real Time (Class A);</li><li>(b) Class B Near Real Time (Class B);</li><li>(c) Class C Mission Critical (Class C); or</li><li>(d) Class D Best Effort (Class D),</li></ul> each of which is prescribed QoS parameters as set out in the table in paragraph 4.2(c);
Committed Information Rate (CIR)	means the minimum bandwidth that Nucleus Connect guarantees over the A-B segment of the diagram in the definition of “QoS”, for each NBAP Per-End-User Connection;

Downlink	means bandwidth in the downstream direction (from Aggregation Network to the End-User);
NBAP Per-End-User Connection	means one connection from the Aggregation Layer to the Service Port(s) in Nucleus Connect’s NTE at the NBAP specified by the Contracting QP in its Order, and “ <b>NBAP Per-End-User Connections</b> ” means more than one NBAP Per-End-User Connection;
Peak Information Rate (PIR)	means the maximum bandwidth that each NBAP Per-End-User Connection can reach over the A-B segment of the diagram in the definition of “QoS”, in the absence of any sort of traffic aggregation, congestion or multiplexing;
Quality of Service or (QoS)	means the service levels committed for ensuring delivery of services over the A-B segment of the diagram below, measured by Jitter, Latency and Packet Loss as set out in the table in paragraph 4.2(c);

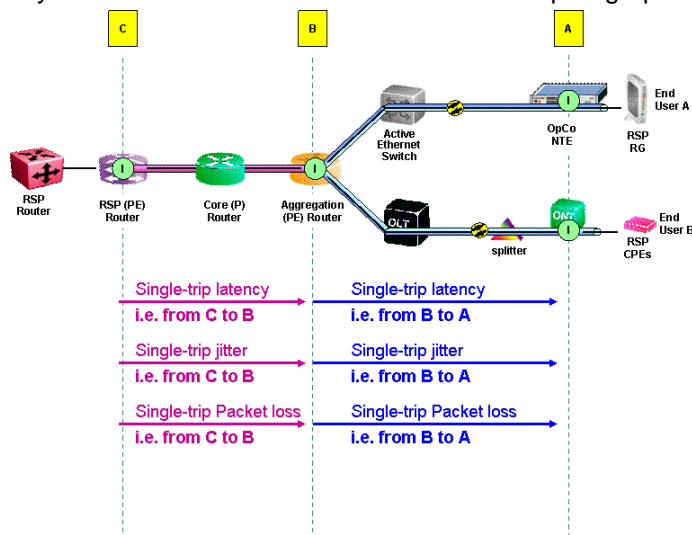

Service Port	means the physical port which the Contracting QP’s or End-User’s equipment shall interface to the Active Network for the purpose of receiving or using each NBAP Per-End-User Connection;
Symmetrical	means equal bandwidth for Uplink and Downlink (between the End-User and the Aggregation Network); and
Uplink	means bandwidth in the upstream direction (from the End-User to the Aggregation Network).

### 3. COMMENCEMENT

This Service Schedule shall commence with effect from the date that the Contracting QP first places an Order to take up an NBAP Per-End-User Connection, in accordance with the General Service Terms and Conditions.

**4. SERVICE REQUIREMENTS**

4.1 The Contracting QP shall place one (1) Order for each NBAP Per-End-User Connection. For example, if the Contractor wishes to take up two (2) NBAP Per-End-User Connections, the Contracting QP shall submit two (2) separate Orders.

4.2 When placing an Order for a NBAP Per-End-User Connection, the Contracting QP shall be required to:

- (a) Choose one Service Port type which is either Fast Ethernet (“**FE Service Port**”) or Gigabit Ethernet (“**GE Service Port**”). In the same Order, the Contracting QP may choose up to two additional Service Ports to be aggregated to the same NBAP Per-End-User Connection provided that all the Service Ports are of the same type,

For FE Service Port(s), each NBAP Per-End-User Connection will have a Symmetrical PIR of 100Mbps.

For GE Service Port(s), each NBAP Per-End-User Connection will have a Symmetrical PIR of 1Gbps.

- (b) Choose any of the following Network Layers:

(i) Option1: Layer 2 VLAN (IEEE 802.1q and IEEE Q-in-Q). Where there is more than one Service Port sharing the same NBAP Per-End-User Connection, each Service Port shall have unique VLAN(s);

(ii) Option 2: Layer 3 IPv4

(iii) Option 3: Layer 3 IPv6,

provided that the availability of Option 2 and Option 3 above are subject to the Contracting QP having taken up and completed the L3 Virtual Routing Domain Setup Service, which is an Ancillary Mandated Service provided by Nucleus Connect.

- (c) Subscribe to at least one Class of Service for such NBAP Per-End-User Connection and indicate the total Symmetrical CIR it wishes to purchase in blocks of 5Mbps provided that:

(i) the combined aggregate Symmetrical CIR for all subscribed Classes of Service shall be no more than 100Mbps for FE Service Port, and 1Gbps for GE Service Port;

(ii) such NBAP Per-End-User Connection shall have at least one (1) Class of Service with:

(I) a minimum Symmetrical CIR of 10Mbps in the case where the Service Port(s) are FE Service Port(s); or

(II) a minimum Symmetrical CIR of 250Mbps in the case where the Service Port(s) are GE Service Port(s).

The Contracting QP may subsequently from time to time, increase or decrease the Symmetrical CIR of each Class of Service subscribed for such NBAP Per-End-User Connection, in blocks of 5Mbps, provided that subparagraphs (i) to (ii) above is complied with. Such increase or decrease of Symmetrical CIR shall constitute a Modification for which the Contracting QP

shall be required to submit an Order pursuant to and in accordance with the General Service Terms and Conditions.

The tables below show the performance parameters of the Class of Services for NBAP Per-End-User Connection.

<b>Class Of Service</b>	<b>Jitter</b>	<b>Latency</b>	<b>Packet Loss</b>
Class A Real Time	0.5ms	4ms	0.2%
Class B Near Real Time	1ms	8ms	0.2%
Class C Mission Critical	3ms	15ms	0.1%
Class D Best Effort	Best Effort	30ms	Best Effort

- 4.3 If the Contracting QP injects traffic into any NBAP Per-End-User Connection which exceeds the Symmetrical CIR purchased for such NBAP Per-End-User Connection pursuant to paragraph 4.2(c), the Contracting QP acknowledges and agrees that notwithstanding that Nucleus Connect will endeavour to deliver such excess traffic, such delivery is not guaranteed. For the avoidance of doubt, the Contracting QP shall not be able to inject traffic into any NBAP Per-End-User Connection which exceeds the PIR as set out in paragraph 4.2(a).
- 4.4 The Contracting QP must adhere to Nucleus Connect's QoS tagging scheme when sending or receiving data traffic through any NBAP Per-End-User Connection from the relevant Service Port(s). Such QoS tagging scheme requires the use of priority bit value 5 for Class A, priority bit value 4 for Class B, priority bit value 2 for Class C and priority bit value 1 for Class D.
- 4.5 If the Contracting QP requires Nucleus Connect to perform QoS tagging on behalf of the Contracting QP, such tagging shall be on a one C-VLAN and one CoS per Service Port basis.
- 4.6 In connection with the installation of the NBAP Per-End-User Connection, the Contracting QP is to provide the following:
- (a) Power Supply rated 240Volts, 13 Ampere, 16 watt, 50/60Hz;
  - (b) a physically secured structure to mount Nucleus Connect's equipment weighing not more than 3.5Kg and not larger than 400 mm x 400 mm x 150 mm (Height x Width x Depth);
  - (c) an environment with an operating temperature between minus 40 Degree Celsius and 65 Degree Celsius; and
  - (d) safety gear, equipment and/or escort and access by qualified personnel in the event that the NBAP is in a hazardous, dangerous and/or under-developed environment, except where Nucleus Connect is reasonably expected to own and provide the same.
- 4.7 The Contracting QP acknowledges that for the purpose of providing NBAP Per-End-User Connections hereunder, Nucleus Connect may need to subscribe for NBAP services from OpenNet. Accordingly, the Contracting QP agrees that the provision of NBAP Per-End-User Connection by Nucleus Connect hereunder shall be further

subject to OpenNet’s terms and conditions for its provision of NBAP services to Nucleus Connect.

4.8 In relation to any NBAP Per-End-User Connection taken up by the Contracting QP, if the Contracting QP wishes to:

- (a) change the then existing Service Port type in respect of such NBAP Per-End-User Connection (from FE Service Port to GE Service Port or vice versa); and/or
- (b) add or reduce the number of Service Ports aggregated to such NBAP Per-End-User Connection, provided that the number of Service Ports sharing such NBAP Per-End-User Connection shall not exceed three (3) at all times,

each such event shall constitute a Modification for which the Contracting QP shall be required to submit an Order pursuant to and in accordance with the General Service Terms and Conditions.

**5. CHARGES**

The Charges set out in this paragraph 5 are the rates payable by the Contracting QP on a NBAP Per-End-User Connection basis.

5.1 Monthly Recurring NC Charges

Nucleus Connect will commence charging the Contracting QP the Monthly Recurring NC Charges specified below on the RFS Date.

NBAP Per-End-User Connection (100Mbps Port)		Monthly Recurring NC Charge	
		First 10Mbps	Next 5Mbps (up to 100Mbps aggregate)
Class of Service	Real Time	\$396.00	\$8.00
	Near Real Time	\$393.60	\$6.80
	Mission Critical	\$390.40	\$5.20
	Best Effort	\$388.00	\$4.00

NBAP Per-End-User Connection (1Gbps Port)		Monthly Recurring NC Charge	
		First 250Mbps	Next 5Mbps (up to 1000Mbps aggregate)
Class of Service	Real Time	\$1,330	\$8.00
	Near Real Time	\$1,270	\$6.80
	Mission Critical	\$1,190	\$5.20
	Best Effort	\$1,130	\$4.00

If the Contracting QP requires an additional Service Port or additional two (2) Service Ports pursuant to paragraph 4.2(a), there will be an additional Monthly Recurring Charge of \$20 for each additional Service Port.

5.2 One-Time Charges

The Charges set out below are non-refundable once they are imposed on the Contracting QP by Nucleus Connect in the manner specified below. In addition, depending on when the relevant action is preferred by the Contracting QP to be undertaken by Nucleus Connect, the following multiplier factor will be applied to the NC Charges set out below. For the avoidance of doubt, the multiplier factor to be applied shall be one (1) unless the Contracting QP requests that the relevant action be undertaken by Nucleus Connect on off-working hours during Business Day(s) or on non Business Day(s).

	Period	Time		Multiplier Factor
Business Day	Monday to Friday	Working Hours	9.00am to 5.00pm	1
	Monday to Friday	Off-working hours	Before 9am and after 5.00pm	1.5
Non-Business day	Saturday, Sundays and Public Holidays	Throughout		2

(a) Cancellation Charge

Upon any Cancellation of any Order or Approved Project Schedule relating to NBAP Per-End-User Connection by the Contracting QP, the following Charges shall be imposed on the Contracting QP:

- (i) an NC Charge of \$50 if Cancellation happens before Nucleus Connect's acknowledgement of its receipt of the Order or an NC Charge of an amount equal to the applicable NC Charges as set out in paragraph 5.2 if Cancellation happens after Nucleus Connect's acknowledgement of its receipt of the Order;
- (ii) ON Charges, except those ON Charges which would be subject to paragraph 5.2(a)(iv), which have been incurred by Nucleus Connect, or which Nucleus Connect has committed to incur, at the time of such Cancellation;
- (iii) any Third Party Charges which have been incurred by Nucleus Connect, or which Nucleus Connect has committed to incur, at the time of such Cancellation; and
- (iv) any other third party charges, OpenNet's charges and/or ON Charges agreed pursuant to paragraph 5.2 or 6.3 of the General Service Terms and Conditions which have been incurred by Nucleus Connect, or which Nucleus Connect has committed to incur, at the time of such Cancellation.

(b) Installation Charge

- (i) Upon the installation of a NBAP Per-End-User Connection by Nucleus Connect, the following Charges shall be imposed on the Contracting QP:

- (a) the following NC Charges:

Description	NC Charges
Installation charge	\$1,500
Charge for installation of environmentally hardened NTE	\$500

Provided that if it becomes necessary for Nucleus Connect to install an environmental hardened NTE as part of the installation of such NBAP Per-End-User Connection, Nucleus Connect shall seek the Contracting QP's prior consent to such installation of the environmental hardened NTE in accordance with the process set out in paragraph 6.1. If the Contracting QP does not provide such consent in accordance with the process set out in paragraph 6.1, the Contracting QP acknowledges and agrees that the Order in respect of such NBAP Per-End-User Connection shall be deemed to be Cancelled whereupon paragraph 5.2(a) shall apply; and

(b) such other installation charges as may be set out in the Approved Project Schedule.

(ii) Patching Charge in the NC CO and Co-location Space

(a) A Patching Charge in addition to the Installation Charge will be imposed if Nucleus Connect is required to provide Patching Services. Nucleus Connect may be required to provide Patching Services where the installation address is located at the Co-location Space or the NC CO. This will be charged at \$40 per patch point.

(b) This Patching Service will be provided by Nucleus Connect if required. The Contracting QP will be required to submit a separate Order for this Patching Service.

(c) Modification Charge

An NC Charge of \$100 shall be imposed on the Contracting QP upon the submission of a Modification Order by the Contracting QP.

(d) Maintenance or Repair

(i) Nucleus Connect will charge for every onsite visit or joint investigation according to the length of time spent by Nucleus Connect's representative during such onsite visit or joint investigation respectively, if such onsite visit or joint investigation is requested by the Contracting QP. There will be a minimum charge of \$800 per onsite visit or joint investigation (as the case may be) up to the first two hours. Subsequent hour blocks are charged at \$400 per hour.

(ii) The No Fault Found Charge referred to in the General Service Terms and Conditions is \$350 per Fault report.

(iii) In the event that routine maintenance of the NBAP Per-End-User Connection service requires the use of safety gear, equipment and/or escort and access by qualified personnel, such requirement shall be provided by the Contracting QP to Nucleus Connect unless Nucleus Connect is reasonably expected to own and provide the same.

(e) Disconnection

Upon a disconnection of a NBAP Per-End-User Connection by reason of suspension pursuant to the ICO Agreement, an NC Charge of \$750 shall be imposed on the Contracting QP.

(f) Deactivation

Upon the Deactivation of a NBAP Per-End-User Connection, the following Charges shall be imposed on the Contracting QP:

(i) the following NC Charges:

Description	Charges
Deactivation Charge	\$750
Early Termination Charge	100% of remaining contract value

(ii) ON Charges, except those ON Charges which would be subject to paragraph 5.2(f)(iv), which have been incurred by Nucleus Connect, or which Nucleus Connect has committed to incur, at the time of such Deactivation;

(iii) any Third Party Charges which have been incurred by Nucleus Connect, or which Nucleus Connect has committed to incur, at the time of such Deactivation; and

(iv) any other third party charges, OpenNet's charges and/or ON Charges agreed pursuant to paragraph 5.2 or 6.3 of the General Service Terms and Conditions which have been incurred by Nucleus Connect, or which Nucleus Connect has committed to incur, at the time of such Deactivation.

**6. CHANGES FROM THE GENERAL SERVICE TERMS AND CONDITIONS**

6.1 Paragraph 5.1 of the General Service Terms and Conditions

For the purpose of this Service Schedule, where the Contracting QP requires the NBAP Per-End-User Connection, paragraph 5.1 of the General Service Terms and Conditions shall not apply and the following provisions of this paragraph 6.1 shall apply instead:

“(a) The Contracting QP acknowledges and agrees that in order for Nucleus Connect to provide the NBAP Per-End-User Connection to the Contracting QP, Nucleus Connect will need to request OpenNet to provide Nucleus Connect with the relevant NBAP connection, which will (if such request is accepted by OpenNet) involve a project study being undertaken by OpenNet (the “**OpenNet Project Study**”).

(b) If an Order to take up a NBAP Per-End-User Connection is not rejected by Nucleus Connect, Nucleus Connect will provide a project schedule (the “**Project Schedule**”) to the Contracting QP within ten (10) Business Days from the completion of the OpenNet Project Study stating (i) the period within which Nucleus Connect will activate such NBAP Per-End-User Connection, (ii) an estimation of Nucleus Connect's, OpenNet's and any third party charges involved and (iii) such other terms and conditions relating to the provision of such NBAP Per-End-User Connection as Nucleus Connect may specify. In addition, in situations where OpenNet requires Nucleus Connect to agree on certain ON Charges and Nucleus Connect intends to on-pass such ON Charges to the Contracting QP, Nucleus Connect and the Contracting QP

shall also agree on such ON Charges before Nucleus Connect proceeds to incur such ON Charges.

- (c) The Contracting QP will be able to raise to Nucleus Connect any terms that are not acceptable to it in the Project Schedule within five (5) Business Days from its receipt thereof, failing which the Contracting QP shall be deemed to have accepted and agreed to the terms in the Project Schedule in its entirety and such Project Schedule shall constitute an Approved Project Schedule.
- (d) If the Contracting QP and Nucleus Connect are unable to reach a mutual agreement on the terms of a Project Schedule within ten (10) Business Days after such Project Schedule is made available to the Contracting QP:
  - (i) the Order which is the subject of such Project Schedule shall be deemed to be Cancelled whereupon paragraph 5.2(a) shall apply; and
  - (ii) such Project Schedule and this Service Schedule shall, unless Nucleus Connect is separately providing NBAP Per-End-User Connection for the Contracting QP at the time, in which case this Service Schedule shall remain in force.

Nucleus Connect shall not unreasonably reject the Contracting QP's request for extension of the said ten (10) Business Days timeframe to reach a mutual agreement on the terms of the Project Schedule.

- (e) As soon as practicable after the mutual agreement of the Contracting QP and Nucleus Connect to the terms of a Project Schedule (as modified or with such additional terms as the Contracting QP and Nucleus Connect may require), the Contracting QP shall confirm in writing to Nucleus Connect that the Contracting QP agrees to the terms of such Project Schedule in their entirety (and such agreed Project Schedule shall hereinafter be referred to as an "**Approved Project Schedule**") within the ten (10) Business Days timeframe (or as the case may be, the agreed extended timeframe) referred to in paragraph 6.1(d) above, whereupon the Approved Project Schedule shall be binding on Nucleus Connect and the Contracting QP.
- (f) If the Contracting QP subsequently does not wish to proceed with an Approved Project Schedule, that shall be deemed to be a Cancellation whereupon paragraph 5.2(a) shall apply."

# Application Form

## Non-Building Address Point (NBAP) Per-End-User Connection



ATTN: NUCLEUS CONNECT, ORDER DESK  
 FACSIMILE NO.: (65) 6808 2820  
 EMAIL: orderdesk@nucleusconnect.com

### Type of Order

- New Order                       Modification                       Disconnection  
 Others (Please specify): \_\_\_\_\_  
 Existing Service ID (Mandatory field unless New Order): \_\_\_\_\_

### Business Customer Information

Company Details	Authorised Officer Particulars
Name of Firm/Company as in RCB:	Name of Authorised Officer as in NRIC/PASSPORT/FIN*. Please underline surname. (Dr/Mr/Miss/Mrs/Mdm):_
Registered Address as in RCB:	NRIC/PASSPORT/FIN* No. of Authorised Officer (Dr/Mr/Miss/Mrs/Mdm):
	E-mail of Authorized Officer:
Main Office Contact No.:	Designation:
Main Office Fax No.:	Contact No. (Office):_
Business Registration Number (BRN):	Contact No. (Fax):
Account Information (For New Accounts, please refer to <a href="http://www.nucleusconnect.com">www.nucleusconnect.com</a> for instruction to sign up Nucleus Connect's Services)	<input type="checkbox"/> Account Number:
Customer Reference ID : (This ID is issued by customer for their internal reference of the service that is set out in this application form)	

### Billing Details (If different from Business Customer Information)

Company Name:	Billing Address :_
City & Postal Code:	Country:
Contact Person Name (Billing):	Customer Contact Number :
Customer Fax Number:	E-mail:

\* Please select where appropriate

### Customer Technical Contact

Installation Contact (for service delivery)	Operations/Technical Contact (after service delivery)
Name:	Name:
Telephone (O):	Telephone (O):
Mobile:	Mobile:
Email:	Email:
Notification Mode: 24 Hours Daily <input type="checkbox"/> Office Hours (9am-5pm, Mon-Fri) <input type="checkbox"/>	Notification Mode: 24 Hours Daily <input type="checkbox"/> Office Hours (9am-5pm, Mon-Fri) <input type="checkbox"/>

# Application Form

## Non-Building Address Point (NBAP) Per-End-User Connection



Instruction					
<b>Bandwidth option:</b>					
The Order Form shall only reflect the final CoS/CIR combination to be effected by this Order. At all times, the NBAP Per-End-User Connection must have at least one Class of Service with:					
(i) a minimum Committed Information Rate (CIR) of 10Mbps Symmetrical in the case where the Service Port(s) are FE Service Port(s); or					
(ii) a minimum Committed Information Rate (CIR) of 250Mbps Symmetrical in the case where the Service Port(s) are GE Service Port(s).					
Note: Unique VLAN shall be assigned for each service port; no two service ports shall share the same VLAN.					
Type of Service Port					
<input type="checkbox"/> Fast Ethernet UTP (100Mbps) <input type="checkbox"/> Gigabit Ethernet UTP (1Gbps) <input type="checkbox"/> Others: _____ <input type="checkbox"/> Additional Service Ports: _____ (Aggregated to the same End-User-Connection) <input type="checkbox"/> Environmental hardened NTE					
NBAP Service Port Installation Location	GPS Co-ordinate: _____ Elevation above floor: _____			Description:	
Site Contact:	Name:			Contact number:	
Network Layer Configuration					
Network protocol options	<input type="checkbox"/> L2 VLAN IEEE802.1q <input type="checkbox"/> L2 VLAN IEEE q-in-q <input type="checkbox"/> Layer 3 IPV4 <input type="checkbox"/> Layer 3 IPV6 <input type="checkbox"/> untagged				
Class Of Service	Committed Information Rate per CoS (Multiple of 5Mbps)	VLAN ID assigned to per CoS	Class Of Service	Committed Information Rate per CoS (Multiple of 5Mbps)	VLAN ID assigned to per CoS
CoS: _____	Bandwidth: _____	VLAN : _____	CoS: _____	Bandwidth: _____	VLAN : _____
CoS: _____	Bandwidth: _____	VLAN : _____	CoS: _____	Bandwidth: _____	VLAN : _____
Service Destination at Aggregation	<input type="checkbox"/> PB-EVC Svc ID: _____ <input type="checkbox"/> PB-EVC Svc ID: _____ <input type="checkbox"/> PB-EVC Svc ID: _____		<input type="checkbox"/> AG-EVC Svc ID: _____ <input type="checkbox"/> AG-EVC Svc ID: _____ <input type="checkbox"/> AG-EVC Svc ID: _____		<input type="checkbox"/> IP Multicast ID: _____ <input type="checkbox"/> IP Multicast ID: _____
<b>Dynamic routing information (BGP Configuration)</b>			<b>Static Routing information</b> <b>PE: Provider Equipment; CE: Customer Equipment</b>		
<input type="checkbox"/> L3 Virtual Routing Domain: _____ <input type="checkbox"/> VLAN: _____ <input type="checkbox"/> BGP ASN: _____ <input type="checkbox"/> MD5 Password: _____		<input type="checkbox"/> Prefix1: _____ <input type="checkbox"/> Prefix2: _____ <input type="checkbox"/> Prefix3: _____ <input type="checkbox"/> Additional Attachment: _____		<input type="checkbox"/> L3 Virtual Routing Domain: _____ <input type="checkbox"/> VLAN: _____ PE-CE IP Subnet : _____ CE LAN IP Subnet : _____ <input type="checkbox"/> Additional Attachment: _____	
Service Port Configuration					
Service Port A: VLAN: _____		Service Port B: VLAN: _____		Service Port C: VLAN: _____	
Contract Period					
Minimum term <sup>Ⓐ</sup>	<input type="checkbox"/> 12 months <input type="checkbox"/> Others (Please specify): _____				
Customer requested RFS Date <sup>Ⓐ</sup>					
Additional Information					

<sup>Ⓐ</sup> Subject to agreement, resource availability and confirmation by Nucleus Connect.

<sup>Ⓑ</sup> If Minimum Term is not specified, the Contracting QP shall be deemed to have selected 12 months.

Customer Signature		
We hereby agree to subscribe to the abovementioned services on the terms and subject to the conditions contained in the Master ICO Agreement and the Service Schedule for the abovementioned services, which terms and conditions shall apply upon Nucleus Connect's acceptance of this application. We certify that all information provided by us herein are true, correct and complete. Further, we agree that any cancellation of the abovementioned services may result in a charge to us at Nucleus Connect's prevailing rates.		
Signature of Authorised Officer	Date	Company Stamp
For Nucleus Connect Use		
<input type="checkbox"/> Application Rejected:		Reason for rejection:
<input type="checkbox"/> Application Accepted		Service ID/s: _____      Work Order No.: _____
No. of pages attached (Excluding application forms):	Approval code:	Processed by (Name, Contact, Signature and Date)